

Exclusively from your Caterpillar® dealer

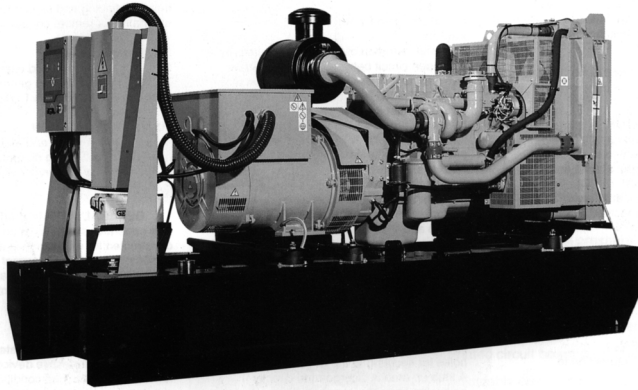

STANDBY 150-200 kW
PRIME 135-180 kW
60 Hz

Model	Standby kW (kVA)	Prime kW (kVA)
D150P4*	150 (187.5)	135 (168.8)
D200P4*	200 (250)	180 (225)

*EPA Approved, Emissions Certified

FEATURES

GENERATOR SET

- Complete system designed and built at ISO 9001 certified facilities
- Factory tested to design specifications at full load conditions

ENGINE

- Governing, electronic
- Electrical system, 24 VDC
- Cartridge type filters
- Battery(s), rack and cables
- Coolant and lube drains piped to edge of base

GENERATOR

- Insulation system, class H
- Electrical design in accordance with BS5000 Part 99, IEC34-1, VDE0530, UTE51100, NEMA MG-1.22
- Drip proof alternator air intake (NEMA 2, IP23) (D150P4)

CONTROL SYSTEM

- 2001 Series Autostart control panel
- Vibration isolated NEMA 1 enclosure with lockable hinged door
- DC and AC wiring looms

MOUNTING ARRANGEMENT

- Heavy-duty fabricated steel base with lifting points
- Anti-vibration pads to ensure vibration isolation
- Complete OSHA guarding
- Stub-up pipe ready for connection to silencer pipework
- Flexible fuel lines to base with NPT connections

COOLING SYSTEM

- Radiator and cooling fan complete with protective guards
- Standard ambient temperatures up to 122° F (50° C)

CIRCUIT BREAKER

- UL/CSA listed
- 3-pole with solid neutral
- NEMA 1 steel enclosure, vibration isolated
- Electrical stub-up area directly below circuit breaker

AUTOMATIC VOLTAGE REGULATOR

- Voltage within ± 0.5% at steady state from no load to full load
- Provides fast recovery from transient load changes

EQUIPMENT FINISH

- All electroplated hardware
- Anticorrosive paint protection
- High gloss polyurethane paint for durability and scuff resistance

QUALITY STANDARDS

- BS4999, BS5000, BS5514, IEC34, VDE0530, NEMA MG-1.22, NFPA 110 (with optional equipment)

DOCUMENTATION

- Operation and maintenance manuals provided
- Wiring diagrams included

WARRANTY

- 12 months from date of initial start-up or 18 months from shipping, whichever occurs first

Materials and specifications are subject to change without notice.

STANDBY 150 - 200 kW
PRIME 135 - 180 kW
60 Hz

OLYMPIAN™

Exclusively from your Caterpillar® dealer

OPTIONAL EQUIPMENT*

ENCLOSURE

- B Series weather protective enclosure (includes internal silencer system and 8-hour single-walled fuel tank)
 - Single point lift
 - Panel viewing window
 - External emergency stop pushbutton
- Sound attenuated enclosure (includes internal silencer system)

SILENCER SYSTEM — OPEN UNIT

- Level 1 “residential”
- Level 2 “critical”
- Level 3 “super critical”
- Mounting kits
- Through-wall installation kits

ENGINE

- Battery heater
- Lube oil drain pump
- High lube oil temperature shutdown
- Lube oil sump heater

CIRCUIT BREAKER

- Auxiliary voltfree contacts
- Shunt trip (100+ amp breakers)

GENERATOR

- Anti-condensation heater
- Drip proof alternator air intake (NEMA 2, IP23) (D200P4)
- Permanent magnet generator
- AREP excitation system
- Alternator upgrade 1 size (D200P4)

CONTROL SYSTEM

- No control system
- 4001 Autostart control panel
- 4001E Autostart control panel
- Access 4000 digital control panel

MOUNTING ACCESSORIES

- Seismic (Zone 4) vibration isolators

FUEL SYSTEM

- Single-walled metal fuel tank
- UL listed closed top-diked skid-mounted fuel tank base (12/24-hour capacity) with fuel alarm (low level/leak detected)
- Critical high fuel alarm
- Skidbase in lieu of tankbase on enclosed sets
- Manual fuel pump

COOLING SYSTEM

- Coolant heater
- Low coolant temperature alarm
- Low coolant level shutdown
- Radiator transition flange

REMOTE ANNUNCIATORS

- 8- and 16-channel remote annunciator panel (supplied loose)
- Remote annunciator upgrade normal/run control switch
- Remote annunciator upgrade lockdown emergency stop button

MISCELLANEOUS ACCESSORIES

- Toolkit
- Additional operator’s manual pack
- Special enclosure color
- CSA certification
- French language labels

EXTENDED WARRANTY

- 24 months
 - 36 months
 - 48 months
 - 60 months
- (See warranty policy for details of coverage)

TESTING

- Factory witness test (restricted to 6 hours — full load, 1.0 pf)

*Some options may not be available on all models. Not all options are listed.

GENERATOR SET DIMENSIONS AND WEIGHTS

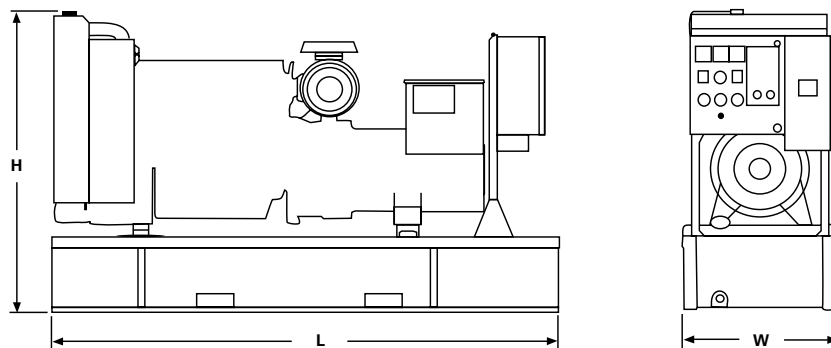

Model	Length in (mm)	Width in (mm)	Height in (mm)	Weight lbs (kg)**
D150P4	117 (2971)	39.5 (1003)	67.6 (1717)	3940 (1787)
D200P4	117 (2971)	39.5 (1003)	67.6 (1717)	4271 (1937)

NOTE: General configuration not to be used for installation. See specific dimensional drawings for detail.

**Includes oil and coolant

STANDBY 150 - 200 kW
PRIME 135 - 180 kW
60 Hz

OLYMPIAN™

Exclusively from your Caterpillar® dealer

SPECIFICATIONS



GENERATOR

Voltage Regulation ±0.5% at steady state from no load to full load
 Frequency ±0.25% for constant load, no load to full load
 Waveform Distortion..... THD < 1.8%, at no load
 Radio Interference Compliance with BS800 and VDE Class G&N
 Telephone Interference TIF <50, THF <2%
 Overspeed Limit..... 2250 rpm
 Insulation Class H
 Temperature Rise Within Class H limits
 Available Voltages 277/480, 266/460, 120/240, 127/220, 120/208, 347/600
 Deration Consult factory for available outputs
 Ratings At 86° F (30° C), 500 ft. (152.4 m), 60% humidity, 0.8 pf



ENGINE

Manufacturer Perkins
 Type 4-Cycle
 Cylinder Configuration In-line 6
 Displacement — cu in (L) 531 (8.7)
 Bore — in (mm) 4.59 (116.6)
 Stroke — in (mm) 5.35 (135.9)
 Governor
 Type Electronic
 Class..... A1
 Piston Speed — ft/sec (m/sec) 26.9 (8.2)
 Engine speed — rpm..... 1800
 Air Cleaner Type Dry, replaceable paper element type with restriction indicator

D150P4 — 1306E87T

Compression Ratio 17.2:1
 Max Power at Rated rpm — hp (kW)
 Standby..... 230 (172)
 Prime..... 207 (154)
 BMEP — psi (kPa)
 Standby 191 (1317)
 Prime..... 172 (1170)
 Regenerative Power — kW..... 28.6
 Aspiration Turbocharged

D200P4 — 1306E87TA

Compression Ratio 16.9:1
 Max Power at Rated rpm — hp (kW)
 Standby..... 325 (242)
 Prime..... 295 (220)
 BMEP — psi (kPa)
 Standby 269 (1855)
 Prime..... 245 (1686)
 Regenerative Power — kW..... 28.6
 Aspiration Turbocharged, AA Charge Cooled



CONTROL PANEL

NEMA 1 steel enclosure with lockable hinged door
 Vibration isolated mounted Autostart control panel
 Single location customer connector point
 Electrical stub-up area directly below control panel

RATING DEFINITIONS

Standby — Applicable for supplying continuous electrical power (at variable load) in the event of a utility power failure. No overload is permitted on these ratings. The generator is peak rated (as defined in ISO8528-3).

Prime — Applicable for supplying continuous electrical power (at variable load) in lieu of commercially purchased power. There is no limitation to the annual hours of operation and the generator set can supply 10 percent overload power for 1 hour in 12 hours.

Consult your Olympian representative for more information.

www.CAT-ElectricPower.com

© 2000 Caterpillar
 All rights reserved.
 Printed in U.S.A.

STANDBY 200 kW
PRIME 180 kW
60 Hz

OLYMPIAN™

Exclusively from your Caterpillar® dealer

D200P4 (3-Phase)

Materials and specifications are subject to change without notice.

Generator Set Technical Data — 1800 rpm/60 Hz		Standby	Prime
Power Rating	kW (kVA)	200 (250)	180 (225)
Lubricating System Type: Full Pressure Oil Filter: Spin-On, Full Flow Oil Cooler: Watercooled Oil Type Required: API CF-4 Total Oil Capacity Oil Pan	U.S. gal (L) U.S. gal (L)	7.0 (26.5) 6.0 (22.7)	7.0 (26.5) 6.0 (22.7)
Fuel System Generator Set Fuel Consumption 100% Load 75% Load 50% Load	g/hr (L/hr) g/hr (L/hr) g/hr (L/hr)	16.18 (61.26) 11.75 (44.5) 8.03 (30.4)	14.29 (54.1) 10.85 (41.46) 7.85 (29.76)
Engine Electrical System Voltage/Ground: 24/Negative Battery Charging Alternator Ampere Rating	amps	55	55
Cooling System Water Pump Type: Centrifugal Radiator System Capacity Incl. Engine Maximum Coolant Static Head Coolant Flow Rate Minimum Temperature to Engine Temperature Rise Across Engine Heat Rejected to Coolant at Rated Power Total Heat Radiated to Room at Rated Power Radiator Fan Load	U.S. gal (L) ft H ₂ O (m H ₂ O) U.S. gal/hr (L/hr) °F (°C) °F (°C) Btu/min (kW) Btu/min (kW) hp (kW)	9.8 (37.2) 51.0 (15.5) 5559.8 (21 060) 174 (79) 5.4 (3.0) 6216 (110) 2561 (45) 20.7 (15.5)	9.8 (37.2) 51.0 (15.5) 5559.8 (21 060) 174 (79) 5.4 (3.0) N/A N/A 20.7 (15.5)
Air Requirements Combustion Air Flow Maximum Air Cleaner Restriction Radiator Cooling Air Alternator Cooling Air	cfm (m ³ /min) in H ₂ O (kPa) cfm (m ³ /min) cfm (m ³ /min)	712 (20.2) 25 (6.2) 16,949 (480) 1420 (40.2)	N/A 25 (6.2) 16,949 (480) 1420 (40.2)
Exhaust System Maximum Allowable Backpressure Exhaust Flow at Rated kW Exhaust Temperature at Rated kW — Dry Exhaust	in Hg (kPa) cfm (m ³ /min) °F (°C)	3.2 (10.7) 1811 (51.3) 890 (477)	3.2 (10.7) N/A N/A
Generator Set Noise Rating* (Without Attenuation) at 3 ft (1 m)	dB(A)	97	97

Alternator Technical Data		347/600V	277/480V	266/460V	120/240V 120/208V	127/220V
Motor Starting Capability: (kVA) (30% Voltage Dip)	Self Excited	480	480	440	360	400
	PM Excited**	510	510	460	380	425
	AREP Excited	TBA	TBA	TBA	TBA	TBA
Full Load Efficiencies:	Standby	92.5	92.5	92.3	91.5	92.0
	Prime	92.8	92.8	92.6	92.0	92.4
Reactances (per unit): Reactances shown are applicable to the standby rating.	X _d	3.21	3.21	3.49	4.27	3.82
	X' _d	0.156	0.156	0.167	0.200	0.178
	X'' _d	0.091	0.091	0.099	0.121	0.108
	X _q	1.92	1.92	2.10	2.57	2.29
	X'' _q	0.112	0.112	0.122	0.149	0.133
	X ₂	0.101	0.101	0.110	0.136	0.121
	X ₀	0.006	0.006	0.006	0.006	0.006
Time Constants:	t' _d 0.100 sec	t'' _d 0.010 sec	t' _{do} 2.116 sec	t _a 0.015 sec		

* dB(A) levels are for guidance only
 ** With PMG Excited Option AR12